

## Elster® TRZ2

Turbine Gas Meter

Sizes from DN50 to 150 (2" to 6")

### Applications

Custody Transfer approved Gas Flow Measurement from low to high operating pressures.

Gas Distribution, Industrial and Commercial applications

### Brief information

Honeywell Elster TRZ2 turbine gas meters are robust meters used to accurately and reliably measure gas consumption in gas distribution, industrial plants or for commercial users. Over decades they have proven to be highly accurate from the first calibration on to the end of their lifetime many years later. This is why leading gas distribution companies around the globe rely on the TRZ2 for their standard gas metering applications.

The patented Honeywell Elster metering cartridge enables repeatable measurement results even under non-ideal inlet flow condition and additionally reduces service time in the field significantly in case the cartridge shall be replaced. Due to its design ambient condition changes (e.g. a drop in temperature) have minimal impact on the meter performance as the cartridge is decoupled from the meter body.

For sizes larger than 6" Honeywell offers the SM-RI-X turbine gas meter which is available up to 24".

### Operating Principle

The gas flowing through the meter sets the turbine wheel in motion. The number of revolutions of the wheel is proportional to the volume passing through the meter. To optimize measurement performance a patented flow straightener eliminates flow disturbances such as swirl or asymmetric flow that are e.g. created by bends or T-pieces upstream of the meter. After the flow conditioner the cross section of the meter is reduced to increase flow velocity and consequently increase the driving impulse of the medium on the turbine wheel.

The combination of flow conditioning and optimized measurement unit incl. the turbine wheel make it possible to measure the flow rate accurately even at low flows and pressures. The shaft on which the turbine wheel is fixed is held in place by robust ball bearings that help to maintain high performance for a long time with minimized maintenance needs. Via gears and a magnetic coupling the revolutions of the turbine wheel are transmitted to the 8-digit mechanical counter located in the pressure-less index head.

The outlet of the meter has been optimized to decrease pressure loss and create optimal flow conditions after the meter.

\* DN 50/2" without patented flow straightener (inlet pipe length  $L > 5$  DN required)



## FEATURES & BENEFITS

- MID approval for fiscal measurement
- Conformity to EN12261, PED, ASME, ATEX and IECEx
- Lowest measurement uncertainty
- High repeatability
- Patented Measuring Cartridge
- Aluminum flow straightener
- Meter sizes G65 to G1.000
- Max. measuring range 5 to 1.600 m<sup>3</sup>/h
- Nominal diameters DN 50 to 150 (2" to 6")
- Operating pressure from 0 to 100 barg
- Flange rating in PN 10-100 and ANSI 150-600
- Temperature range: -25 °C to +70 °C (acc. MID)
- Compact installation with inlet pipe length  $L \geq 2$  DN
- Thermowell built into meter housing (optional)
- Integrated HF-pulsar (optional)
- Absolute ENCODER (optional)
- Direct mount of Honeywell EVC (optional)
- Designed for natural gas, town gas, butane, air, nitrogen, other gases on request

### Pulse outputs

The TRZ2 can be equipped with low and high frequency outputs depending on customer requirements.

#### Low frequency (standard)

- 2x LF outputs (type E1) with maximum frequency of 0.5 Hz
- 1x manipulation contact

The standard IN-S10 pulse output is delivered with 2.5m open-ended 6-wire cable to be connected directly to an EVC or junction box. Optionally the IN-S11 and IN-S12 offer a 6-pin flange plug and one/two connector sockets.

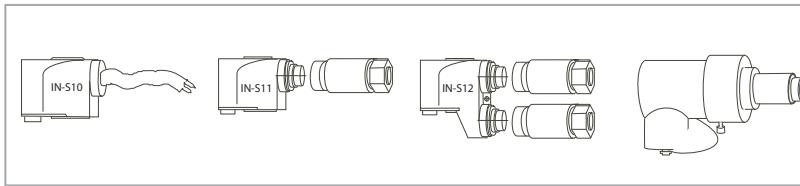

#### High frequency (optional)

- up to 4x HF outputs
- max. 2x of type A1S which pick up the revolutions of the turbine wheel blades
- max. 2x of type A1R which pick up the revolutions of the turbine wheel by scanning boreholes on the inside of the wheel.

#### Measurement Uncertainty

The TRZ2 turbine gas meter is designed and manufactured according to the European Standard for turbine meters EN 12261.

As a standard the TRZ2 fulfill the error limit requirements of EN12261 which are as follows:

- $\pm 1\%$  for  $0.2 Q_{max}$  to  $Q_{max}$
- $\pm 2\%$  for  $Q_{min}$  to  $0.2 Q_{max}$

#### Measuring ranges

Standard measurement range is 1:20. Depending on the operating pressure MID allows for higher measuring ranges.

Please contact the factory for more details.

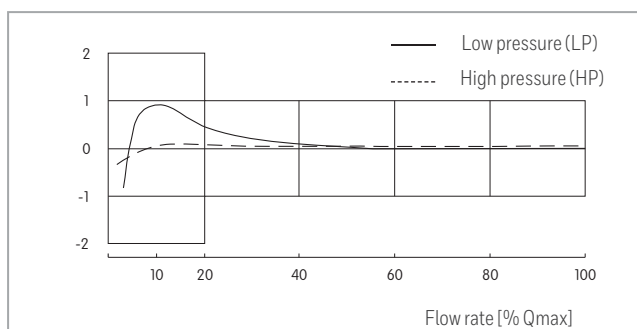

### S1 index head

The rugged design of the meter index (including the plastic cover) has proven itself in the harshest environments and is IP67 certified. The S1 index head is equipped with an 8-digit mechanical index for continuous meter reading. For better usability the index head can be rotated by 350° without breaking any seals.

Two low frequency outputs (reed contacts) are included as a standard and can be connected to any Flow Computer or Electronic Volume Corrector. An additional switch is included to monitor manipulation attempts from the outside



### Approvals and Conformity

Elster TRZ2 turbine gas meters are manufactured in accordance with DIN EN ISO 9001:2008 (DIN EN ISO 14001).

They are designed, produced and tested in accordance with the following guidelines, standards and references.

#### General

European Standard for Turbine Meters EN 12261  
OIML Provision R137-1

#### Metrology

- EC directive 2014/32/EU (MID)

#### Hazardous Area

- EC directive 2014/34/EU (ATEX)

#### Pressure Equipment

- EC directive 2014/68/EU (PED)

$$Q_{min, HP} = Q_{min, LP} \cdot \frac{1}{\sqrt{d_v \cdot p}}$$

$d_v$  = density ratio of gas (natural gas  $d_v = 0.65$ )  
 $p$  = actual absolute pressure [bar]

**Pressure loss TRZ2, Reference density natural gas  $\rho = 0.83 \text{ kg/m}^3$**

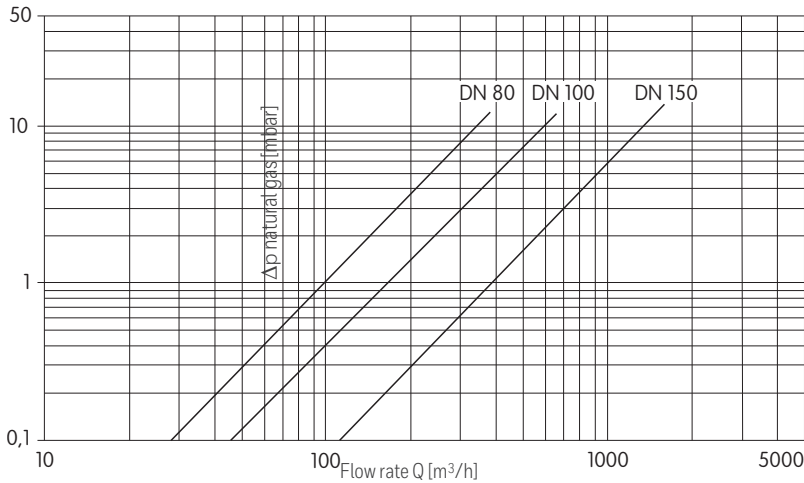

Pressure loss under operating conditions:

$$\Delta p_b = \Delta p_1 \cdot \rho_b$$

Density under operating conditions:

$$\rho_b = \rho_n \cdot \frac{p_b}{p_{atm}}$$

Pressure loss for any gas G:

$$\Delta p_b = \Delta p_{ng} \cdot \frac{\rho_G}{\rho_{ng}}$$

Sign	Description	Unit
$\rho_b$	Absolute operating pressure (overpressure)	kg/m <sup>3</sup>
$\Delta p_1$	Pressure loss for natural gas at 1 bar	kg/m <sup>3</sup>
$\Delta p_b$	Pressure loss for natural gas at operating conditions	kg/m <sup>3</sup>
$\Delta p_{ng}$	Pressure loss for natural gas	kg/m <sup>3</sup>
$\Delta p_G$	Pressure loss for any gas	bar

Sign	Description	Unit
$\rho_b$	Density in operating condition	kg/m <sup>3</sup>
$\rho_n$	Density in standard condition	kg/m <sup>3</sup>
$\rho_G$	Density of any gas	kg/m <sup>3</sup>
$\rho_{ng}$	Density of natural gas	kg/m <sup>3</sup>
$p_{atm}$	Absolute atmospheric pressure	bar

**Material**

Meter bodies: ductile iron (GGG-40) or forged steel. Turbine wheel: Aluminum

Note: TRZ2 are fire-proof (HTB) and can therefore be used in critical C&I installations.

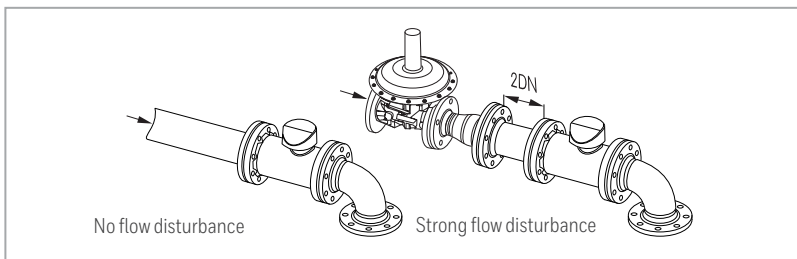
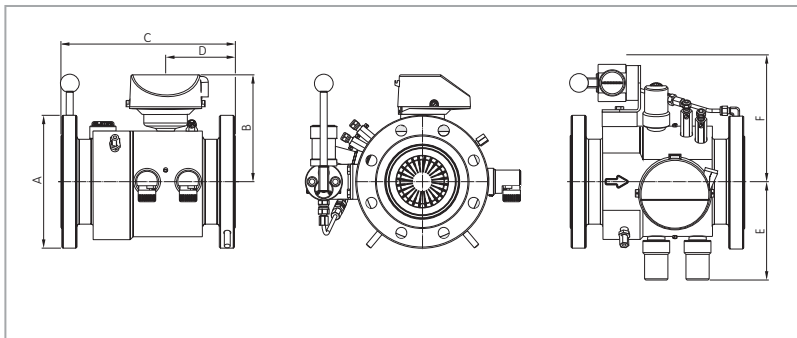

**Installation tips/Mounting position:**

According to EN12261 turbine gas meters can be operated in horizontal and vertical position.

**Inlet pipe:**

≥2 DN independent of flow disturbance for DN 80 – 150 and ≥5 DN for DN 50

**Outlet pipe:**

Fitting in nominal diameter of the meter

# TRZ2: Turbine gas meters Technical Specification

Technical Data														
Measuring data	Diameter	DN	50	80	80	80	100	100	100	150	150	150	150	
	Meter size	G	65	100	160	250*	160	250	400*	250	400	650*	1000*	
	Measuring range	Q <sub>min</sub>		5	8	12,5	20	12,5	20	32	20	32	50	80
		Q <sub>max</sub>		100	160	250	400	250	400	650	400	650	1000	1600
	Δp ** at Q <sub>max</sub>	[mbar]	11	2	5	12	2	5	13	1	2	6	15	
Housing ***	Temperature range	-25 °C to +70 °C												
	Pressure rates	PN 10, 16, 25, 40, 64, 100 / ANSI 150, 300, 600												
	Dimensions	A mm	165	215	215	215	273	273	273	356	356	356	356	
		B mm	155	172	172	172	185	185	185	210	210	210	210	
		C mm	150	240	240	240	300	300	300	450	450	450	450	
		D mm	75	100	100	100	120	120	120	180	180	180	180	
		E mm	135	157	157	157	170	170	170	193	193	193	193	
F mm		280	200	200	200	210	210	210	235	235	235	235		
Weight [kg]***	PN10/16, ANSI150	(GGG)	10	21	21	21	29	29	29	53	53	53	53	
	PN25/40, ANSI300	(steel)	13	32	32	32	50	50	50	91	91	91	91	
	PN64/100, ANSI600	(steel)	15	33	33	33	50	50	50	97	97	97	97	
Outputs / pulse values *** [imp/m <sup>3</sup> ]	LF-Type E1	(Reed switch)	10	1	1	1	1	1	1	1	1	1	0.1	
	HF-Type A1R	(inductive)	28000	10500	10500	10500	6630	6630	6630	6630	2560	2560	2560	
	HF-Type A1S	(inductive)	-	21000	21000	21000	13260	13260	13260	-	5120	5120	5120	

\* Meter also available with measuring range 1:30 \*\* Δp for natural gas at 1bar abs. \*\*\* Small deviations are possible

## For more information

To learn more about Honeywell Elster's Gas Solutions, visit [www.honeywellprocess.com](http://www.honeywellprocess.com) or contact your Honeywell account manager.

## Honeywell Process Solutions

Germany  
 Elster GmbH  
 Steinern Str. 19-21  
 55252 Mainz-Kastel  
 T +49 6134 605 0  
 F +49 6134 605 223  
[www.honeywellprocess.com](http://www.honeywellprocess.com)  
[www.elster-instromet.com](http://www.elster-instromet.com)

Elster® is a registered trademark of Elster GmbH.  
 BR-17-06-ENG ,# 3032 01/17 ©  
 2017 Honeywell International Inc.